

Aluminium Door Transfer

51DG Series

Aluminium Door Transfer/ Non-Vision Grilles

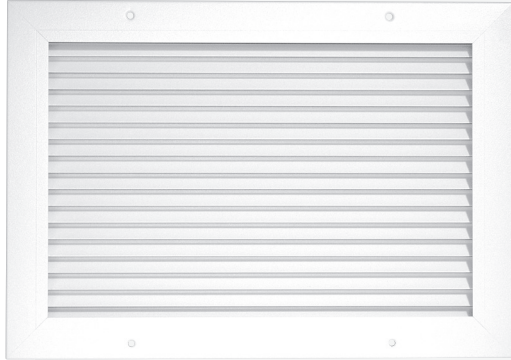

The Advanced Air Model Series 51DG Door Transfer/Non-Vision Grilles are designed to meet the demand for top quality and competitive prices. The grilles are carefully constructed to be unobtrusive in appearance for architectural excellence.

Model Series 51DG offers the largest free area possible (average > 50%) with a completely sight-proof design, utilizing an inverted 'V' shaped louvre on 20mm centres. Widely used, not only in doors and partitions, but also in place of conventional exhaust and return grilles where it is important that the interior of the plenum or duct be concealed. The inverted-V blades not only block vision, but also provide strength. When mounted in the lower portion of a door, a door grille is naturally subjected to bumps and kicks. The 51DG durability assures good looks and long service. Screw holes in the frame are countersunk for smooth appearance after installation.

Available sizes 100mm x 100mm to 600mm x 1200mm in 50mm increments. Other sizes are available on request but are subject to manufacturing limitations.

Material: Extruded aluminium.

Finish: White polyester powder finish RAL9010 semi-gloss is standard. Other finishes are available.

Model 51DGD
Auxiliary Frame Assembly

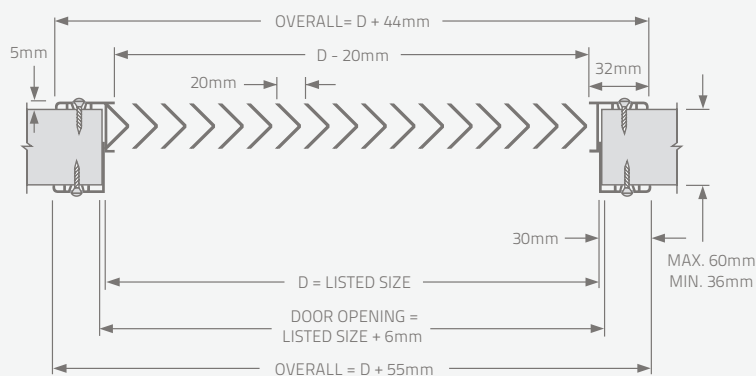

Model 51DGS
Flange Frame Assembly

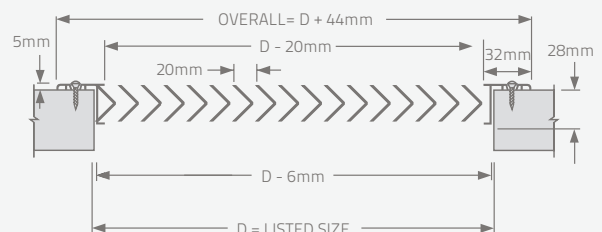



How To Specify or To Order

Aluminium Door Transfer/Non-Vision Grille – Model Series 51DG

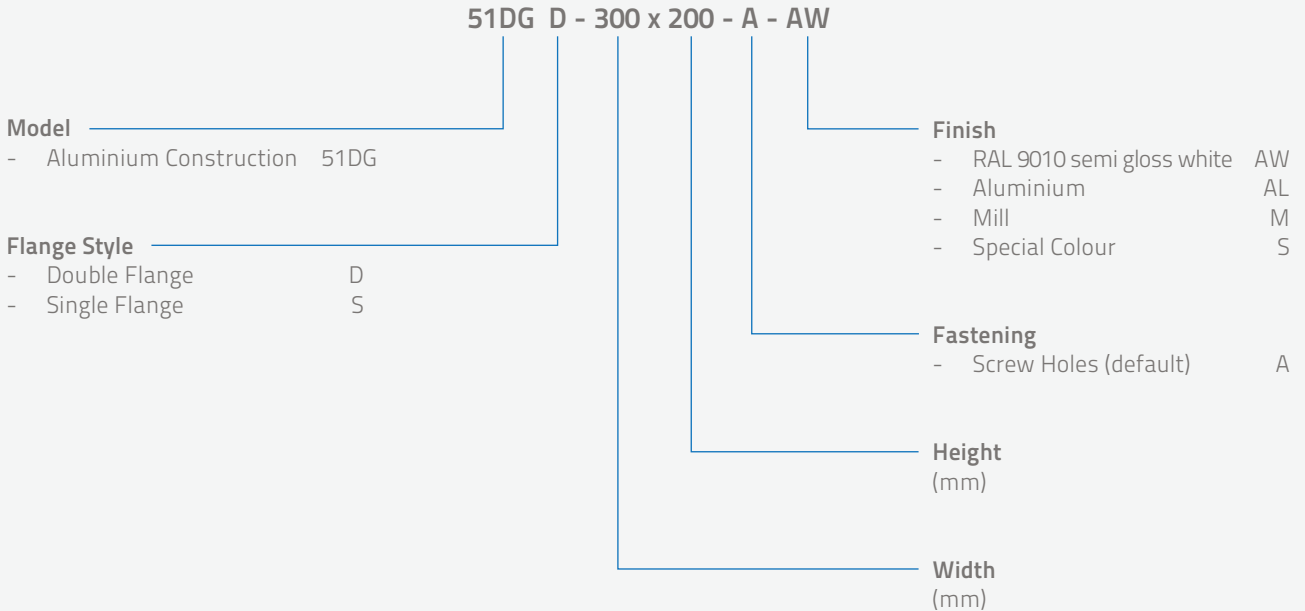

(Show complete Model Number and Size, unless "Default" is desired)

Suggested Specification:

Supply and install Advanced Air Model (specify) 51DGD or 51DGS Door/Transfer Grilles of the type and size as shown on the plans and air distribution schedules. The grille shall have extruded aluminium inverted 'V' shaped blades and an extruded aluminium frame. The door grille is to be sight-proof. The finish shall be White polyester powder finish RAL9010 semi-gloss as standard (optional finishes are available).

Notes:

1. For a standard grille with no special requirements, the "default" will automatically be selected. For example, an aluminium door grille with a double flange, is Model 51DGD. Unit will be supplied with screw holes and White polyester powder finish RAL9010 semi-gloss.
2. Heights available in 50mm increments only.