



Linear Bar Grilles

4900 Series

Linear Bar Grilles

4900 Series

The Model Series 4900 Linear Bar Grilles have been specially designed to provide the precision quality appearance required for architectural excellence with crisply sculptured styling, careful workmanship and effective air distribution.

The Series 4900 Linear Bar Grilles are designed for heating and cooling applications, supply and return.

The grilles are manufactured with precision mitred corners to maximise quality.

- Fixed Bars
- Aluminium Construction

Models:

13mm Bar Spacing

49-240 ■ 6mm Bars ■ 0° Deflection ■ Pencil-Proof

49-241 ■ 6mm Bars ■ 15° Deflection ■ Pencil-Proof

49-243 ■ 6mm Bars ■ 30° Deflection ■ Pencil-Proof

49-280 ■ 3mm Bars ■ 0° Deflection

49-281 ■ 3mm Bars ■ 15° Deflection

6mm Bar Spacing

49-480 ■ 3mm Bars ■ 0° Deflection

49-481 ■ 3mm Bars ■ 15° Deflection

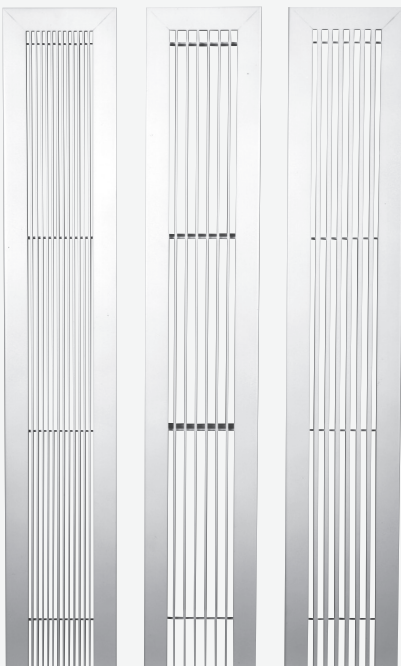



- Features:**
- Deflection bars are fixed and are parallel to the long dimension.
 - Available in 7 core styles and a variety of frame and sub-frame options.
 - Diffusers are supplied in lengths of up to 1800mm in a single section.
 - Standard incremental units of length are 300, 600, 900, 1200, 1500 and 1800. However, the 4900 Series is available in any nominal length to suit engineering and architectural requirements.
 - Ideal for continuous length applications
 - Multiple-sections are supplied with alignment strips on the frame and sub-frame to provide superior, positive site alignment.
 - End caps are staked and mitred for a superior quality appearance.
 - Standard duty models are available for ceiling, wall or sill installations. Heavy duty models are designed specifically for use in floor installations.

- Options:**
- Aluminium opposed blade damper (add suffix 'OA').
 - MC Mitred Corner Sections.
 - BO Blanking Plates
 - Material: Extruded aluminium.
 - Finish: White polyester powder finish RAL 9010 semi-gloss. Other finishes are available.

Available Frame Types and Dimensional Data

Type A

25mm border

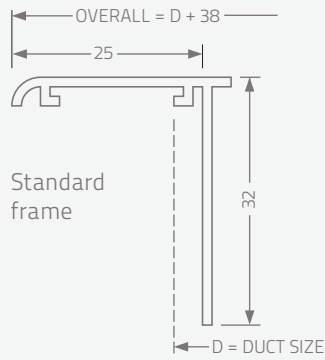

Type B

19mm reduced border

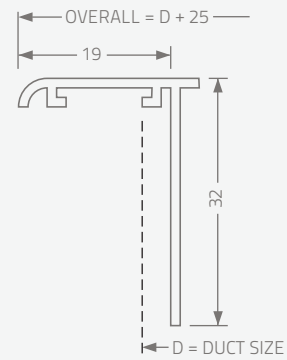

Type D

25mm border

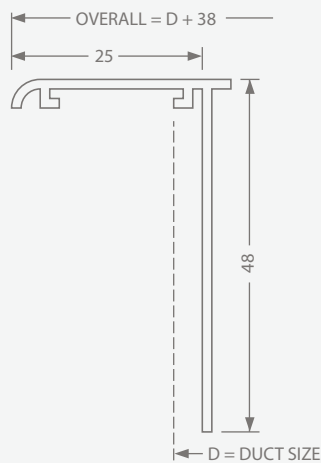

Heavy duty mounting frames for floor installations

Type F

25mm border flange

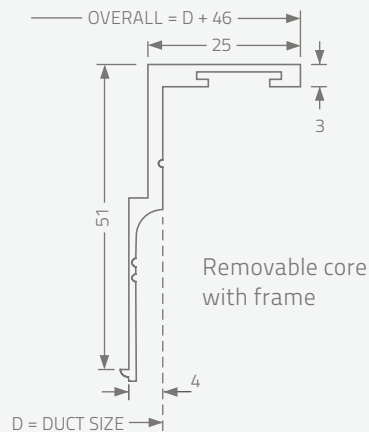

Type G

No flange flush mounting

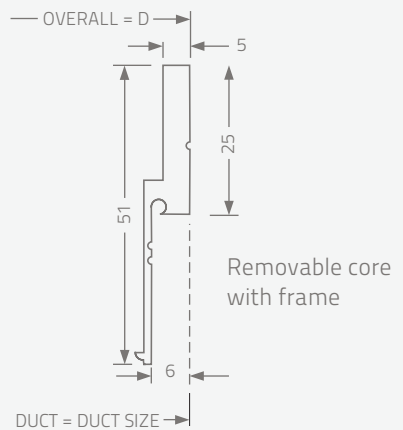



Available Core Styles

Pencil Proof

13mm Spacing, 6mm Bars
Model 49-240 ■ 0° Deflection

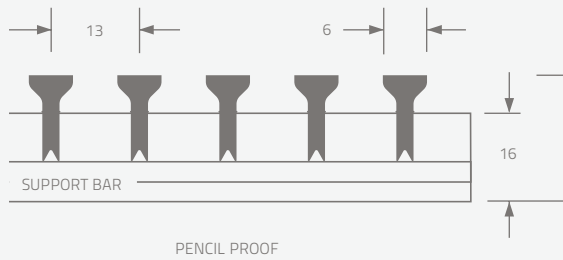

Pencil Proof

13mm Spacing, 6mm Bars
Model 49-241 ■ 15° Deflection

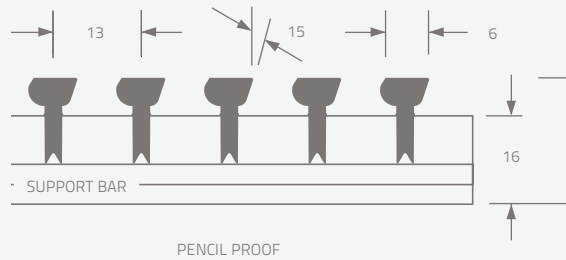

Pencil Proof

13mm Spacing, 6mm Bars
Model 49-243 ■ 30° Deflection

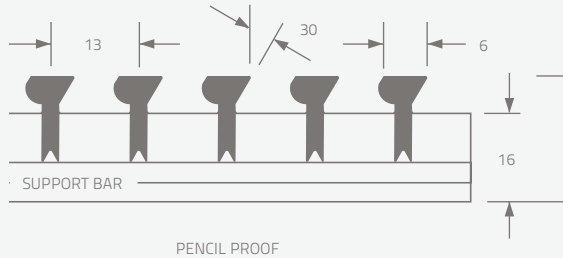

Pencil Proof

13mm Spacing, 3mm Bars
Model 49-280 ■ 0° Deflection

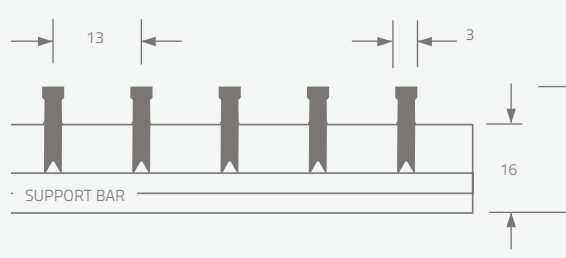

Pencil Proof

13mm Spacing, 3mm Bars
Model 49-281 ■ 15° Deflection

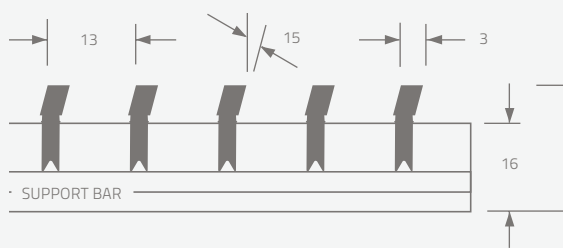

Heel Proof

6mm Spacing, 3mm Bars
Model 49-480 ■ 0° Deflection

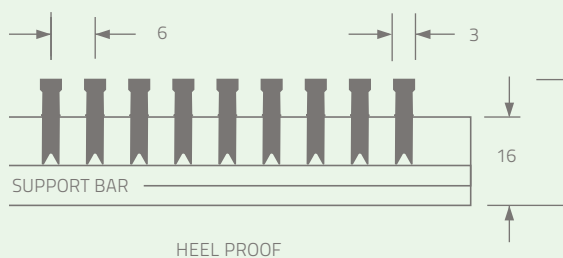

Heel Proof

6mm Spacing, 3mm Bars
Model 49-481 ■ 15° Deflection

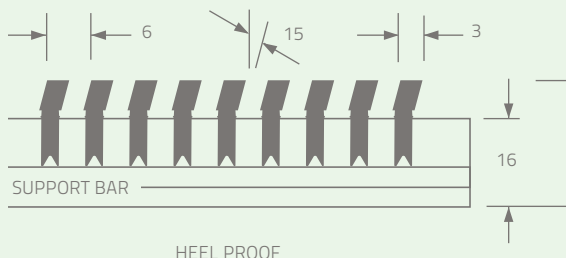

Overall Length and Width Dimensional Data

Frame Types

Type	N	O
A	D - 13mm	D + 38mm
B	D - 13mm	D + 25mm
D	D - 13mm	D + 38mm
E	D - 13mm	D + 13mm
F	D	D + 46mm
G	D	D

Dimensions are for length or width.

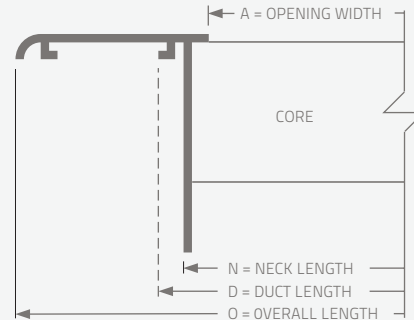

Standard Widths and Core Dimensional Data

Duct Width D	6mm Spacing	
	Opening Width A	Number of Bars
38	19	2
50	31	4
65	45	6
75	56	8
90	71	10
100	81	12
125	106	16
150	131	20

Duct Width D	13mm Spacing	
	Opening Width A	Number of Bars
38	19	1
50	31	2
65	45	3
75	56	4
90	71	5
100	81	6
125	106	8
150	131	10

For frames types F and G increase the number of bars by two. Dimensions are in mm.

Cross-Bar Spacing

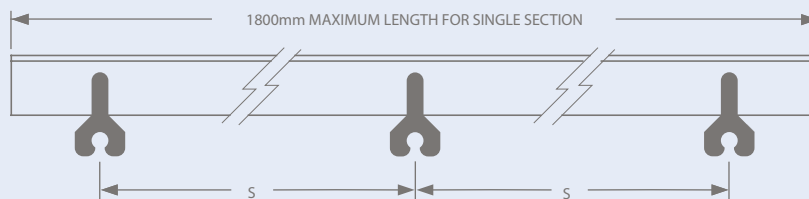

Standard Core: S = 300mm maximum support bar spacing. Frame Types A, B, and D.
 Optional HC Heavy Duty Core: S = 200mm maximum.
 Standard for floor models with frame types F and G, which also include secondary reinforcing support bars.





Typical Frame/Core Assemblies

Core with Frame

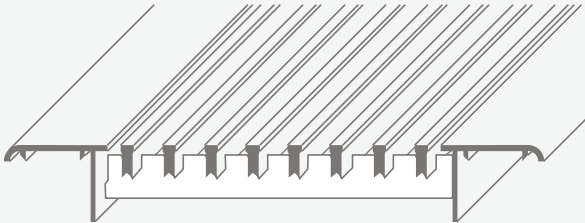

Type A Frame

Core only

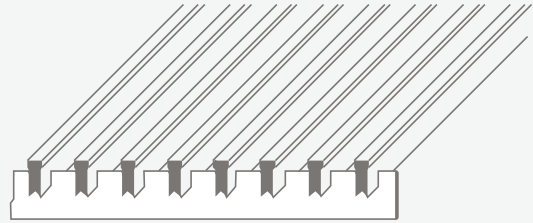

Core with Heavy Duty Mounting Frame

Additional
Cross-Bar
Support

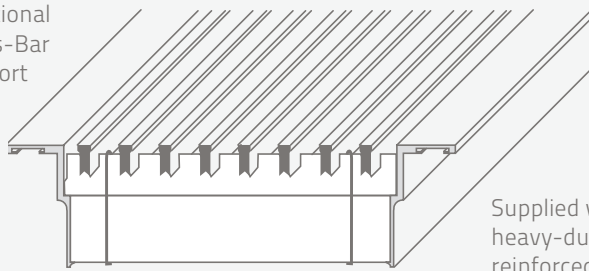

Supplied with
heavy-duty
reinforced core
and core clips

Type F Heavy Duty Mounting Frame

Fastenings

Type A ■ Countersunk Screw Holes

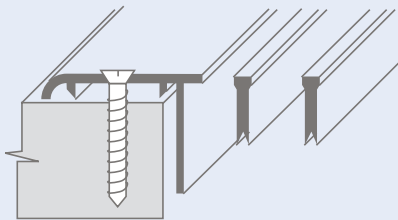

For ceiling, side wall, sill or floor.
Frame Types - A, B, D, F.

Type B ■ Friction Spring Clip

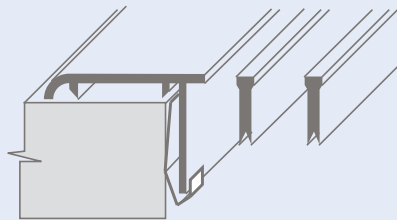

For sill installations.
Frame Types - A, B, E, F, G.

Type C ■ Concealed Mounting

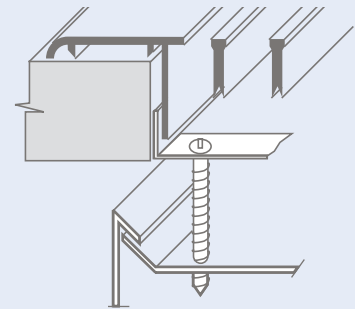

For ceiling, side wall, sill or floor.
Frame Types - A, B, D.
Not recommended for use with
cores with 6mm bar spacing.

Options and Accessories

Type DV Directional Vanes

For all available widths.

Fully adjustable extruded aluminium blades on 19mm centres perpendicular to length.

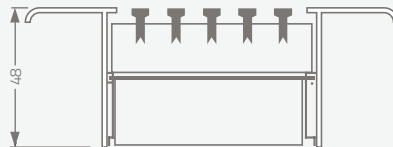

Requires Frame Type D (deep stack), F or G

Opposed Blade Damper

For linear bar grilles with a nominal duct width of 64mm and wider.
Access Doors

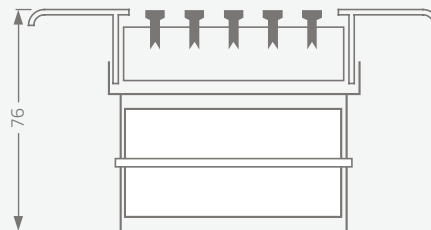

Type BO Steel Blank-Off

For all available widths. Supplied in 1829mm lengths for site cutting.
Steel, painted black.



Alignment Strips

Supplied as standard on multiple-section assemblies to provide positive and accurate site alignment, except frame G which uses alignment pins.

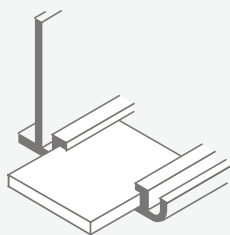



Dimensional Data

Mitred Corner Sections

49-240MC
49-241MC
49-243MC
49-280MC

49-281MC
49-480MC
49-481MC

Floor, Ceiling or Sill

- Type O ▪ 0° deflection
- Type A ▪ Deflection inside
- Type B ▪ Deflection outside

Factory welded with precision to match and align with the associated straight leg.

Standard mitred corner section for floor, ceiling or wall is 90 degrees. Other angles are available.

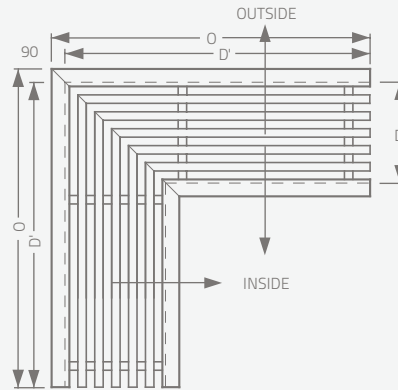

90° Mitred Corner Dimension 'O'

Duct Width D	Duct Length D	Frame Type					
		A, D	B	C	E	F	G
38 – 100	300	319	313	327	306	320	300
101 – 300	450	468	462	605	598	602	449

Continuous Run Dimensions

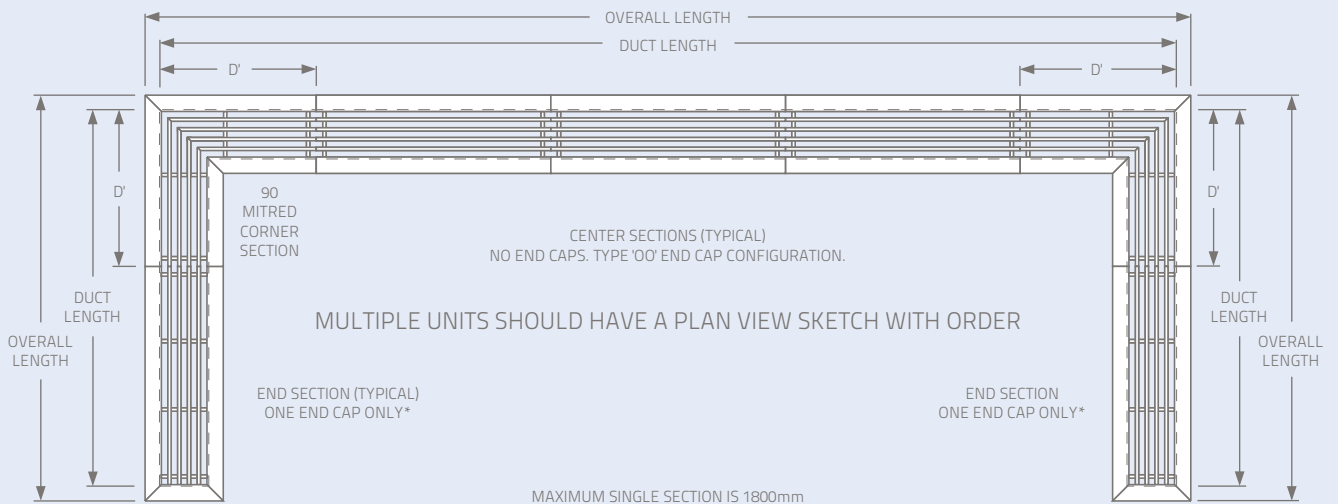

*End sections with single end caps and deflecting cores must be specified and ordered with the desired core deflection direction.

End cap configurations (mitred end cap one end and open opposite end):

Type 'MO' = 0° deflection

Type 'MU' = (15° or 30°)



Type 'MD' = (15° or 30°)

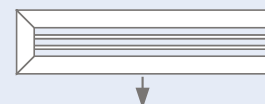

Typical Opening Preparations

Ceiling 1
 Frame Types A, B, D, or E

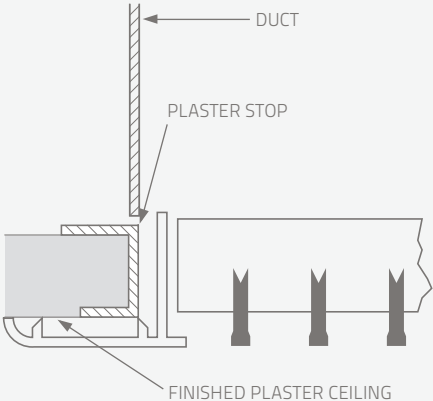

Floor or Sill 1
 Frame Type F

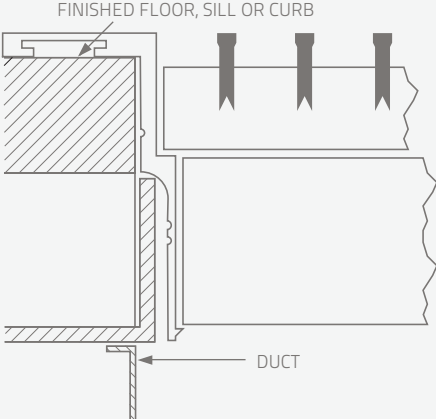

Floor or Sill 2
 Frame Type G

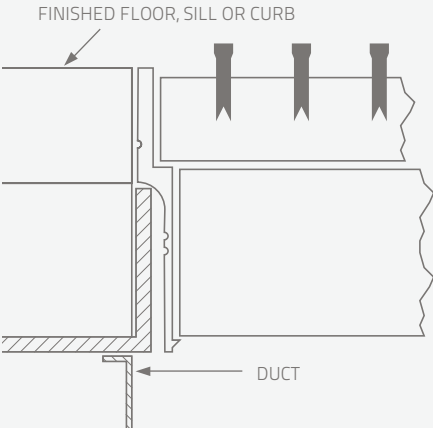

Raised Sill 1
 Core Only

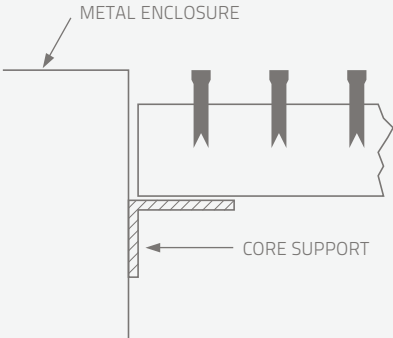

Raised Sill 2
 Frame Types A, B or D

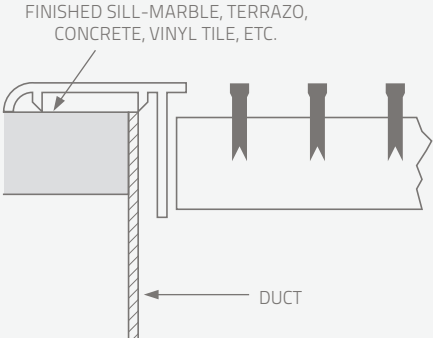

Side Wall 1
 Frame Types A, B or D

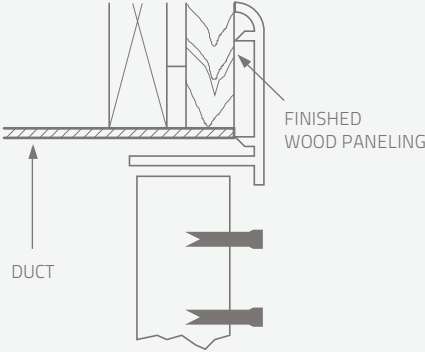





How To Specify or To Order

Extruded Aluminium Linear Bar Grilles ■ Model Series 4900

49 - 2 4 0 - 0 - 1500 x 100 - A - AW - A - MM - AD

<p>Model</p> <ul style="list-style-type: none"> - Linear Bar Grille <p>Bar Spacing</p> <ul style="list-style-type: none"> - 13mm 2 - 6mm 4 <p>Bar Width</p> <ul style="list-style-type: none"> - 6mm 4 - 3mm 8 <p>Bar Deflection</p> <ul style="list-style-type: none"> - 0° 0 - 15° 1 - 30° 3 <p>Damper</p> <ul style="list-style-type: none"> - No Damper (default) — - With Damper OA <p>Length mm</p> <p>Width mm</p> <p>Frame or Frame/Sub-Frame Combination</p> <ul style="list-style-type: none"> - 25mm A - 19mm B - 25mm with deep neck D - 25mm Heavy duty F - No Flange Heavy duty G - Core Only CO 	<p>Accessories</p> <ul style="list-style-type: none"> - Blank-Offs BO - Access Door AD - Heavy duty core HC - Deflector Vanes DV <p>End Cap Configuration</p> <ul style="list-style-type: none"> - Mitred Mitred (default) MM - Open Open OO - Mitred Open 0° MO - Mitred Open 15°, 30° MU <div style="text-align: center;">  <p>- Mitred Open 15°, 30° MD</p>  </div> <p>Fastening</p> <ul style="list-style-type: none"> - None (default) N - Screw Holes A - Spring Clips B - Concealed Mounting C <p>Finish</p> <ul style="list-style-type: none"> - RAL 9010 semi gloss white AW - Aluminium AL - Mill Finish MI - Special SP
---	--

(Show complete Model Number and Size, unless "Default" is desired)

Notes:

1. To use more than one "Accessory", list the items in order and specify description.
2. It is helpful to include a sketch for multiple units with mitred corners.

Performance Data

Model 49-240 ■ 13mm Spacing ■ 6mm Bars ■ 0° Deflection

Free Area (m ²) per Metre Length	Nominal Duct Width (mm)	Pressure Drop (Pa)	2	5	10	15	22	30	39	49	61
0.01	50	Flowrate per Length (l/s/m)	28	42	56	70	84	98	111	125	139
		NC Level	—	—	12	18	23	29	33	36	39
		Throw (m) Sill or Floor Side Wall	0.3 - 0.3 1.5 - 2.1	1.2 - 1.2 2.7 - 3.7	2.1 - 2.1 3.4 - 4.9	2.7 - 3.0 4.3 - 6.1	3.4 - 4.0 5.2 - 7.0	4.3 - 4.9 5.8 - 7.9	4.9 - 5.5 6.4 - 8.5	5.2 - 6.1 6.7 - 9.1	5.8 - 6.4 7.6 - 10.1
0.03	75	Flowrate per Length (l/s/m)	54	82	108	136	164	190	218	245	273
		NC Level	—	—	15	21	27	32	36	39	42
		Throw (m) Sill or Floor Side Wall	0.6 - 0.6 2.1 - 3.0	2.1 - 2.1 3.4 - 4.6	3.0 - 3.4 4.3 - 5.8	4.0 - 4.6 5.2 - 7.0	4.9 - 5.5 6.4 - 8.2	5.8 - 6.4 7.3 - 9.4	6.7 - 7.3 8.2 - 10.4	7.3 - 7.6 9.4 - 11.9	7.9 - 8.2 10.4 - 12.5
0.04	100	Flowrate per Length (l/s/m)	82	124	164	206	248	288	330	370	412
		NC Level	—	—	17	23	29	34	38	41	44
		Throw (m) Sill or Floor Side Wall	0.9 - 0.9 2.3 - 3.4	2.7 - 2.7 4.0 - 5.2	4.0 - 4.0 5.2 - 6.4	4.9 - 5.2 6.4 - 7.9	6.1 - 6.4 7.6 - 9.1	7.0 - 7.3 8.5 - 10.4	7.6 - 7.9 9.1 - 11.3	8.5 - 8.5 10.6 - 12.5	9.4 - 9.4 11.6 - 13.7
0.05	125	Flowrate per Length (l/s/m)	110	164	220	274	328	384	438	492	548
		NC Level	—	10	18	24	30	35	39	42	45
		Throw (m) Sill or Floor Side Wall	1.2 - 1.2 3.0 - 4.0	3.0 - 3.0 4.3 - 5.5	4.6 - 4.6 5.8 - 7.0	5.5 - 5.5 6.7 - 8.2	6.7 - 7.0 8.2 - 9.8	7.6 - 7.6 9.4 - 11.3	8.2 - 8.5 10.1 - 11.9	9.1 - 9.1 11.3 - 13.1	10.4 - 10.4 12.5 - 14.3
0.07	150	Flowrate per Length (l/s/m)	138	206	276	344	412	480	550	619	687
		NC Level	—	11	20	25	31	36	40	43	46
		Throw (m) Sill or Floor Side Wall	1.5 - 1.5 3.4 - 4.3	3.0 - 3.0 4.8 - 6.1	4.6 - 4.6 6.1 - 7.3	5.8 - 5.8 7.3 - 8.8	7.0 - 7.0 8.8 - 10.4	7.6 - 7.6 10.1 - 11.9	8.8 - 8.8 10.6 - 12.2	9.4 - 9.4 12.2 - 13.7	11.0 - 11.0 13.4 - 14.9

Model 49-243 ■ 13mm Spacing ■ 6mm Bars ■ 30° Deflection

Free Area (m ²) per Metre Length	Nominal Duct Width (mm)	Pressure Drop (Pa)	3	6	12	18	26	35	47	59	73
0.01	50	Flowrate per Length (l/s/m)	29	45	59	74	90	104	119	133	149
		NC Level	—	12	20	27	32	37	41	44	47
		Throw (m) Sill or Floor Side Wall	0.3 - 0.3 1.5 - 2.1	1.2 - 1.2 2.4 - 3.7	2.1 - 2.1 3.4 - 4.9	2.7 - 3.0 4.3 - 6.1	3.7 - 4.0 5.2 - 7.3	4.3 - 4.6 5.8 - 7.9	4.9 - 5.5 6.7 - 8.8	5.5 - 6.1 7.0 - 9.4	5.8 - 6.7 7.6 - 10.4
0.03	75	Flowrate per Length (l/s/m)	53	81	107	133	159	186	214	240	266
		NC Level	—	12	20	27	32	37	41	44	47
		Throw (m) Sill or Floor Side Wall	0.6 - 0.6 1.8 - 2.7	1.8 - 1.8 3.4 - 4.6	3.0 - 3.4 4.3 - 5.8	4.0 - 4.3 5.5 - 7.0	4.9 - 5.5 6.4 - 8.2	5.8 - 6.1 7.3 - 9.4	6.4 - 7.0 8.5 - 10.7	7.3 - 7.6 9.1 - 11.6	7.6 - 7.6 10.4 - 12.5
0.04	100	Flowrate per Length (l/s/m)	79	118	158	197	235	276	314	353	393
		NC Level	—	13	21	29	34	39	43	46	49
		Throw (m) Sill or Floor Side Wall	0.9 - 0.9 2.7 - 3.7	2.7 - 2.7 4.0 - 5.2	4.0 - 4.0 5.2 - 6.7	4.9 - 5.2 6.1 - 7.6	6.1 - 6.4 7.3 - 9.1	6.7 - 7.0 8.5 - 10.4	7.6 - 7.9 9.4 - 11.6	8.2 - 8.2 11.0 - 12.5	9.1 - 9.1 11.3 - 13.4
0.05	125	Flowrate per Length (l/s/m)	104	155	207	259	310	362	413	466	517
		NC Level	—	13	21	29	34	39	43	46	49
		Throw (m) Sill or Floor Side Wall	1.2 - 1.2 3.4 - 4.3	3.0 - 3.0 4.6 - 5.8	4.3 - 4.3 5.8 - 7.3	5.5 - 5.5 7.0 - 8.5	6.4 - 6.7 7.9 - 9.8	7.3 - 7.6 9.1 - 11.0	8.2 - 8.5 9.8 - 11.9	9.1 - 9.1 11.0 - 12.8	9.8 - 9.8 11.9 - 14.0
0.06	150	Flowrate per Length (l/s/m)	130	195	260	325	390	455	520	585	650
		NC Level	—	15	23	31	36	41	45	48	51
		Throw (m) Sill or Floor Side Wall	1.5 - 1.5 3.7 - 4.6	3.0 - 3.0 5.2 - 6.4	4.6 - 4.6 6.4 - 7.6	5.8 - 5.8 7.3 - 8.8	7.0 - 7.0 8.8 - 10.4	7.6 - 7.6 9.8 - 11.6	8.5 - 8.8 10.7 - 12.2	9.4 - 9.4 11.6 - 13.1	10.7 - 10.7 12.8 - 14.3

Performance Data

Model 49-280 ■ 13mm Spacing ■ 3mm Bars ■ 0° Deflection

Free Area (m ²) Per metre Length	Nominal Duct Width (mm)	Pressure Drop (Pa)	2	5	9	14	19	27	35	44	55
0.02	50	Flowrate per Length (l/s/m)	34	51	68	85	102	119	136	153	170
		NC Level	—	—	12	18	23	28	32	35	38
		Throw (m) Sill or Floor Side Wall	0.3 - 0.3 1.5 - 2.1	1.2 - 1.2 2.4 - 3.7	2.1 - 2.1 3.4 - 4.9	2.7 - 3.0 4.3 - 6.1	3.4 - 3.7 5.2 - 7.0	4.3 - 4.9 5.8 - 7.9	4.9 - 5.5 6.4 - 8.5	5.2 - 6.1 6.7 - 9.1	5.8 - 6.4 7.6 - 10.1
0.03	75	Flowrate per Length (l/s/m)	59	90	119	149	178	207	238	268	297
		NC Level	—	—	11	17	22	27	31	34	37
		Throw (m) Sill or Floor Side Wall	0.6 - 0.6 2.1 - 3.0	2.1 - 2.1 3.0 - 4.3	3.0 - 3.4 4.3 - 5.8	4.0 - 4.3 5.2 - 7.0	4.9 - 5.2 6.1 - 7.9	5.8 - 6.1 7.3 - 9.1	6.4 - 7.0 8.2 - 10.4	7.3 - 7.6 9.1 - 11.6	7.6 - 7.9 10.1 - 12.5
0.04	100	Flowrate per Length (l/s/m)	87	129	172	215	259	302	344	387	430
		NC Level	—	—	12	18	23	28	32	35	38
		Throw (m) Sill or Floor Side Wall	0.9 - 0.9 2.4 - 3.4	2.7 - 2.7 4.0 - 5.2	4.0 - 4.0 5.2 - 6.4	4.9 - 5.2 6.1 - 7.6	6.1 - 6.4 7.6 - 9.1	7.0 - 7.3 8.5 - 10.4	7.6 - 7.9 9.1 - 11.3	8.2 - 8.2 10.7 - 12.5	9.1 - 9.1 11.6 - 13.4
0.05	125	Flowrate per Length (l/s/m)	111	166	221	277	333	387	443	499	554
		NC Level	—	—	12	18	23	28	32	35	38
		Throw (m) Sill or Floor Side Wall	1.2 - 1.2 3.0 - 4.0	3.0 - 3.0 4.3 - 5.5	4.3 - 4.3 5.8 - 7.0	5.5 - 5.5 6.7 - 8.2	6.7 - 7.0 8.2 - 9.8	7.3 - 7.3 9.1 - 11.0	8.2 - 8.5 10.1 - 11.9	9.1 - 9.4 11.3 - 13.1	9.8 - 9.8 12.5 - 14.3
0.07	150	Flowrate per Length (l/s/m)	136	206	274	342	410	480	548	616	684
		NC Level	—	—	14	20	24	29	33	36	39
		Throw (m) Sill or Floor Side Wall	1.5 - 1.5 3.7 - 4.6	3.0 - 3.0 4.9 - 6.1	4.6 - 4.6 6.1 - 7.3	5.5 - 5.5 7.3 - 8.8	7.0 - 7.0 8.8 - 10.4	7.6 - 7.6 10.1 - 11.9	8.5 - 8.5 10.7 - 12.2	9.4 - 9.4 12.2 - 13.7	9.8 - 9.8 13.4 - 14.9

Model 49-281 ■ 13mm Spacing ■ 3mm Bars ■ 15° Deflection

Free Area (m ²) Per Metre Length	Nominal Duct Width (mm)	Pressure Drop (Pa)	2	5	9	14	19	27	35	44	55
0.02	50	Flowrate per Length (l/s/m)	34	53	70	87	104	121	139	156	173
		NC Level	—	12	20	26	31	36	40	44	47
		Throw (m) Sill or Floor Side Wall	0.3 - 0.3 1.5 - 2.1	1.2 - 1.2 2.4 - 3.7	2.1 - 2.1 3.4 - 4.9	2.7 - 3.0 4.3 - 6.1	3.7 - 4.0 5.2 - 7.0	4.3 - 4.9 5.5 - 7.6	4.9 - 5.5 6.1 - 8.2	5.2 - 6.1 6.7 - 9.1	5.8 - 6.4 7.9 - 10.4
0.03	75	Flowrate per Length (l/s/m)	57	87	115	144	173	201	231	259	288
		NC Level	—	—	17	23	29	34	38	42	45
		Throw (m) Sill or Floor Side Wall	0.6 - 0.6 1.8 - 2.7	1.8 - 1.8 3.0 - 4.3	3.0 - 3.0 4.0 - 5.5	3.7 - 4.0 5.2 - 6.7	4.9 - 5.2 6.1 - 7.9	5.8 - 6.1 7.3 - 9.1	6.4 - 7.0 7.9 - 10.1	7.0 - 7.3 9.1 - 11.3	7.6 - 7.6 9.8 - 11.9
0.04	100	Flowrate per Length (l/s/m)	82	124	164	206	248	288	328	370	412
		NC Level	—	10	18	24	30	35	39	43	46
		Throw (m) Sill or Floor Side Wall	0.9 - 0.9 2.4 - 3.4	2.4 - 2.7 3.7 - 4.9	4.0 - 4.0 5.2 - 6.4	4.6 - 4.9 5.8 - 6.4	5.8 - 6.1 7.3 - 8.8	6.7 - 7.0 8.2 - 10.1	7.3 - 7.6 9.1 - 11.0	7.9 - 8.2 10.1 - 11.9	9.1 - 9.1 11.3 - 13.1
0.05	125	Flowrate per Length (l/s/m)	107	161	214	268	322	375	429	483	536
		NC Level	—	10	18	24	30	35	39	43	46
		Throw (m) Sill or Floor Side Wall	1.2 - 1.2 3.0 - 4.0	2.7 - 2.7 4.3 - 5.5	4.3 - 4.3 5.8 - 7.0	5.2 - 5.2 6.4 - 7.9	6.4 - 6.7 7.6 - 9.4	7.3 - 7.3 8.8 - 10.7	7.9 - 8.2 10.1 - 11.6	8.8 - 8.8 10.7 - 12.5	9.8 - 9.8 11.9 - 13.7
0.06	150	Flowrate per Length (l/s/m)	132	197	263	328	393	458	525	591	657
		NC Level	—	10	18	24	30	35	39	43	46
		Throw (m) Sill or Floor Side Wall	1.5 - 1.5 3.4 - 4.3	3.0 - 3.0 4.9 - 6.1	4.6 - 4.6 6.1 - 7.3	5.5 - 5.5 7.3 - 8.5	7.0 - 7.0 8.2 - 9.8	7.6 - 7.6 9.1 - 11.0	8.5 - 8.5 10.1 - 11.9	9.1 - 9.1 11.3 - 12.8	10.4 - 10.4 12.5 - 14.0

Performance Data

Model 49-480 ■ 6mm Spacing ■ 3mm Bars ■ 0° Deflection

Free Area (m ²) Per Metre Length	Nominal Duct Width (mm)	Pressure Drop (Pa)	3	6	11	17	24	32	43	54	67
0.01	50	Flowrate per Length (l/s/m)	29	43	57	73	87	102	116	130	146
		NC Level	—	—	12	18	23	29	32	36	39
		Throw (m) Sill or Floor Side Wall	0.3 - 0.3 1.5 - 2.1	1.2 - 1.2 2.4 - 3.4	1.8 - 1.8 3.4 - 4.6	2.7 - 2.7 4.3 - 5.8	3.4 - 3.7 4.9 - 6.7	4.0 - 4.6 5.5 - 7.6	4.6 - 5.2 6.1 - 8.2	5.2 - 5.8 6.7 - 8.8	5.5 - 6.1 7.3 - 9.8
0.03	75	Flowrate per Length (l/s/m)	51	77	102	129	155	180	206	231	257
		NC Level	—	—	14	20	26	31	35	38	41
		Throw (m) Sill or Floor Side Wall	0.6 - 0.6 1.8 - 2.7	1.8 - 1.8 3.0 - 4.3	2.7 - 3.0 4.0 - 5.5	3.7 - 4.0 5.2 - 6.7	4.9 - 5.2 6.1 - 7.6	5.8 - 6.1 7.0 - 8.8	6.4 - 6.7 7.9 - 10.1	7.0 - 7.0 9.1 - 11.3	7.6 - 7.6 9.8 - 11.9
0.04	100	Flowrate per Length (l/s/m)	76	113	152	189	226	265	302	341	378
		NC Level	—	—	16	22	29	33	37	40	43
		Throw (m) Sill or Floor Side Wall	0.9 - 0.9 2.4 - 3.4	2.4 - 2.4 3.7 - 4.9	3.7 - 4.0 4.9 - 6.1	4.6 - 4.9 6.1 - 7.6	5.8 - 6.4 7.3 - 8.8	6.4 - 7.0 7.9 - 9.8	7.3 - 7.6 9.1 - 11.0	7.9 - 8.2 10.1 - 11.9	8.8 - 9.1 11.3 - 14.0
0.05	125	Flowrate per Length (l/s/m)	98	146	194	243	291	341	389	437	486
		NC Level	—	—	16	22	28	33	37	40	43
		Throw (m) Sill or Floor Side Wall	1.2 - 1.2 2.7 - 3.7	2.7 - 2.7 4.3 - 5.5	4.3 - 4.3 5.5 - 6.7	5.2 - 5.2 6.4 - 7.9	6.4 - 6.7 7.9 - 9.4	7.3 - 7.3 8.8 - 10.7	8.2 - 8.2 10.1 - 11.9	8.8 - 8.8 11.0 - 12.8	9.8 - 9.8 12.2 - 14.0
0.06	150	Flowrate per Length (l/s/m)	121	180	240	300	361	421	480	540	601
		NC Level	—	10	18	24	30	35	38	42	43
		Throw (m) Sill or Floor Side Wall	1.5 - 1.5 3.0 - 4.0	3.0 - 3.0 4.6 - 5.8	4.6 - 4.6 5.8 - 7.0	5.5 - 5.5 7.3 - 8.5	7.0 - 7.0 8.2 - 9.8	7.6 - 7.6 9.4 - 11.3	8.5 - 8.8 10.4 - 11.9	9.4 - 9.4 11.9 - 13.4	10.4 - 10.4 13.1 - 14.6

Model 49-481 ■ 6mm Spacing ■ 3mm Bars ■ 15° Deflection

Free Area (m ²) Per Metre Length	Nominal Duct Width (mm)	Pressure Drop (Pa)	3	6	12	19	27	37	49	62	76
0.01	50	Flowrate per Length (l/s/m)	31	45	60	76	91	107	121	136	152
		NC Level	—	12	20	27	32	37	41	44	47
		Throw (m) Sill or Floor Side Wall	0.3 - 0.3 1.5 - 2.1	1.2 - 1.2 2.4 - 3.4	1.8 - 1.8 3.4 - 4.6	2.7 - 2.7 4.3 - 5.8	3.4 - 3.7 4.9 - 6.7	4.0 - 4.6 5.5 - 7.6	4.9 - 5.5 6.1 - 8.2	5.2 - 5.8 6.7 - 8.8	5.5 - 6.1 7.3 - 9.8
0.02	75	Flowrate per Length (l/s/m)	51	76	102	127	152	178	203	229	254
		NC Level	—	12	20	27	32	37	41	44	47
		Throw (m) Sill or Floor Side Wall	0.6 - 0.6 1.8 - 2.7	1.8 - 1.8 3.0 - 4.0	2.7 - 2.7 4.0 - 5.2	3.7 - 4.0 4.9 - 6.4	4.6 - 4.9 6.1 - 7.6	5.5 - 5.8 6.7 - 8.5	6.4 - 6.7 7.9 - 9.8	6.7 - 7.0 8.5 - 10.7	7.0 - 7.3 9.4 - 11.9
0.04	100	Flowrate per Length (l/s/m)	73	108	146	181	217	254	290	341	362
		NC Level	—	13	21	28	34	38	42	45	48
		Throw (m) Sill or Floor Side Wall	0.9 - 0.9 2.1 - 3.0	2.7 - 2.7 3.7 - 4.6	3.7 - 3.7 4.9 - 6.1	4.6 - 4.6 5.8 - 7.3	5.8 - 6.1 7.0 - 8.5	6.4 - 6.7 7.9 - 9.8	7.3 - 7.6 8.8 - 10.7	7.6 - 7.9 9.8 - 11.9	8.5 - 8.5 11.0 - 12.8
0.05	125	Flowrate per Length (l/s/m)	94	141	187	235	282	328	376	424	471
		NC Level	—	14	22	29	34	39	43	46	49
		Throw (m) Sill or Floor Side Wall	0.9 - 0.9 2.7 - 3.7	2.7 - 2.7 4.0 - 5.2	4.0 - 4.0 5.5 - 6.7	4.9 - 5.2 6.4 - 7.9	6.1 - 6.4 7.6 - 9.1	7.0 - 7.3 8.5 - 10.4	7.6 - 7.9 9.4 - 11.3	8.5 - 8.5 10.4 - 12.2	9.4 - 9.4 11.6 - 13.4
0.06	150	Flowrate per Length (l/s/m)	115	172	231	288	345	403	461	519	576
		NC Level	—	14	22	30	35	40	43	47	50
		Throw (m) Sill or Floor Side Wall	1.2 - 1.2 3.0 - 4.0	3.0 - 3.0 4.3 - 5.5	4.3 - 4.3 5.8 - 7.0	5.5 - 5.5 7.0 - 8.2	6.7 - 6.7 8.2 - 9.4	7.6 - 7.6 9.1 - 10.7	8.5 - 8.5 10.1 - 11.9	9.1 - 9.1 11.3 - 12.8	9.8 - 9.8 12.2 - 13.7



Rev.	Date	Change	Int.
A	25/04/16	First Issue	AF
B	16/09/16	ECN 929	RJ

- Note:
1. Spot weld or button lock construction,
 2. Plenum shown is 600mm length with 200mm Spigot, with Dim. 'W' referring to a 4900 Series Linear Bar Grille with neck dimension 100mm.
 3. For End Cap & Assembly details please see overleaf.
 4. Dim. 'W' refers to neck dimension of 4900 Series Linear Bar Grille.

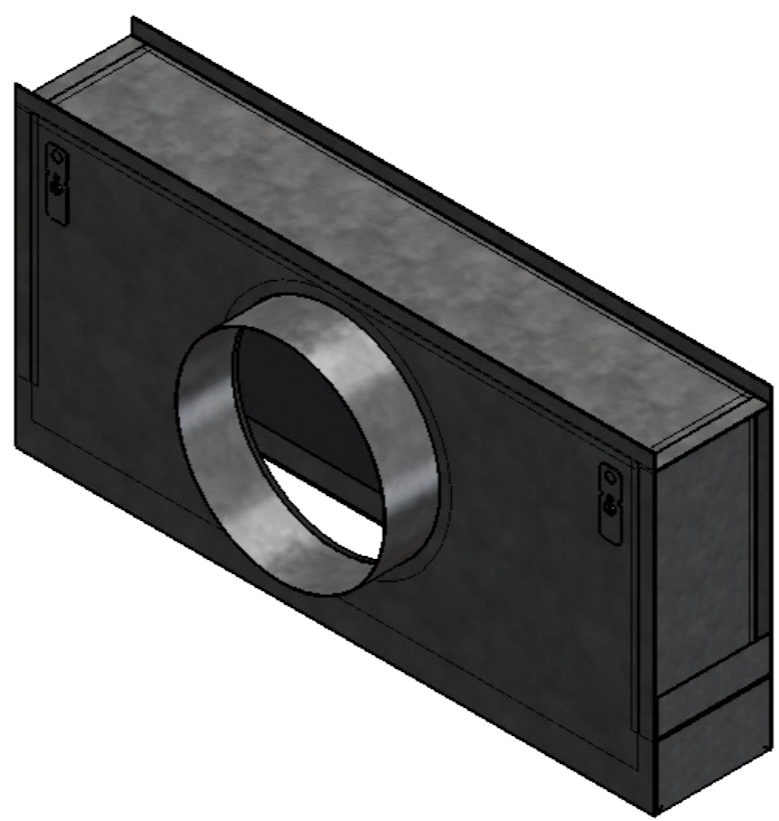

Material: 0.80mm Galvanised Mild Steel
To BS EN 10346 : 2015 DX51 D + Z 275

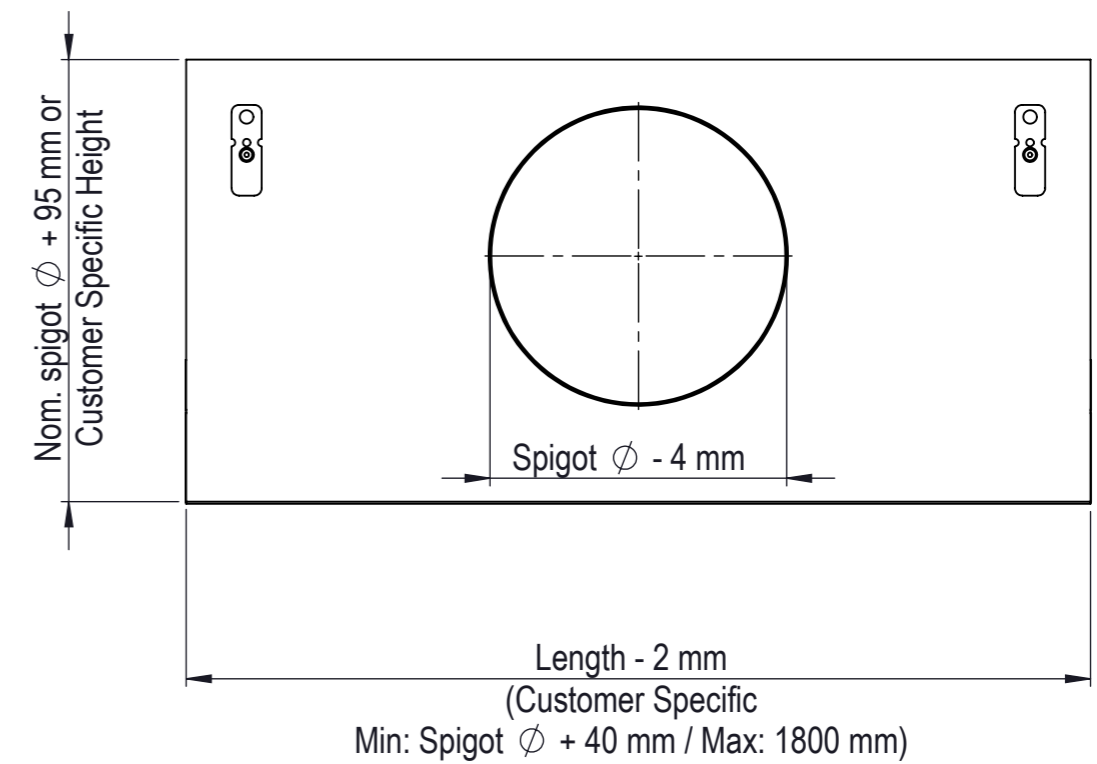
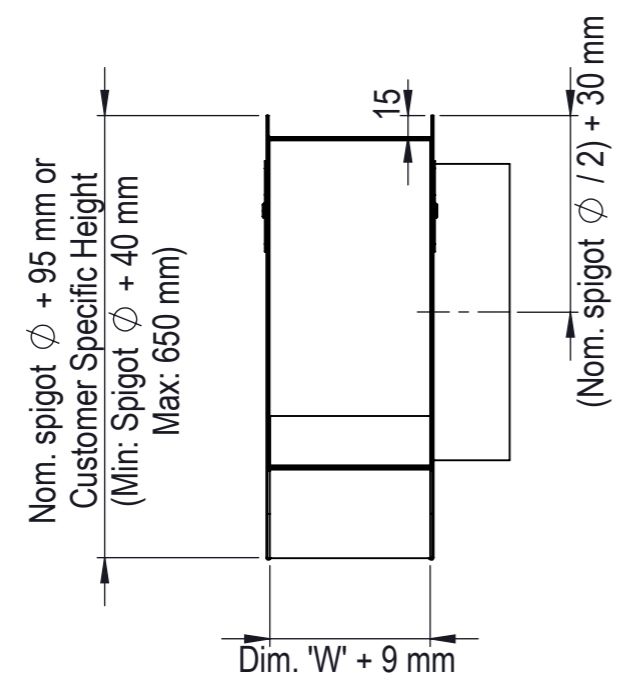

PRIVATE & CONFIDENTIAL
NOT TO BE
REPRODUCED WITHOUT
THE PERMISSION OF
ADVANCED AIR (UK) LTD.
ADVANCED AIR (U.K.) LTD. RESERVE THE RIGHT TO MAKE DESIGN CHANGES WITHOUT NOTICE
AS PART OF OUR CONTINUOUS IMPROVEMENT PROCESS.

TOLERANCES (Unless Otherwise Stated)
0.0mm ± 0.5mm
0.00mm ± 0.2mm
Angles ± 0.5 Degrees

Advanced Air (U.K.) Limited
 Reg'd Office: Burrell Way, Thetford,
 Norfolk, IP24 3QU, England
 Telephone : (01842) 765657 Fax : (01842) 753493

TITLE :
 4900P Series
 4900 Series Plenum - Concealed Fix Type
 Side Entry (49-200 A & B Frame Only)
 Customer Drawing

Date : 25/04/16	
Scale: 1:5	
Sheet 1 OF 2	
Drg. No. : 4900P CD001	A3

Rev.	Date	Change	Int.
A	25/04/16	First Issue	AF
B	16/09/16	ECN 929	RJ

End Cap Configuration Details:

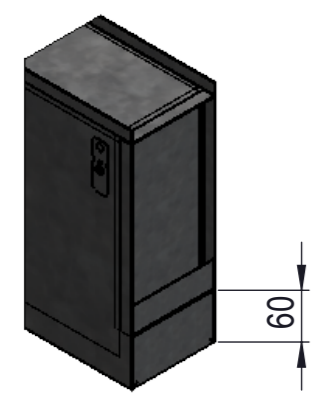

Plenum End Cap As Supplied (With or Without OBD)

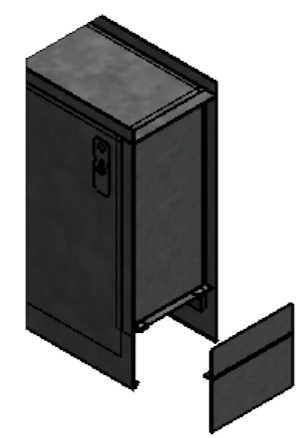

Remove Plenum End Cap

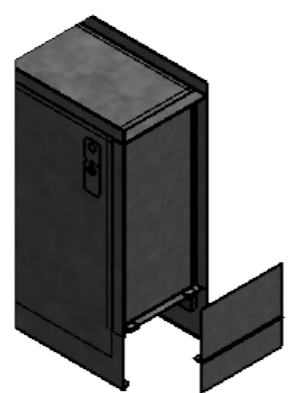

Invert Plenum End Cap (Rotate 180°)

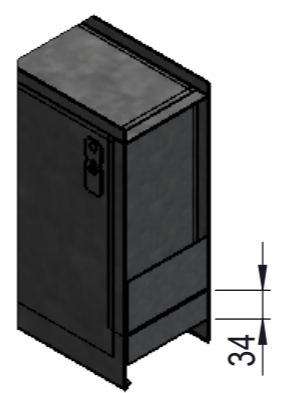

Refit for Intermediate Plenum Without OBD



Remove End Cap and Discard for Intermediate Plenum With OBD

Assembly Details:

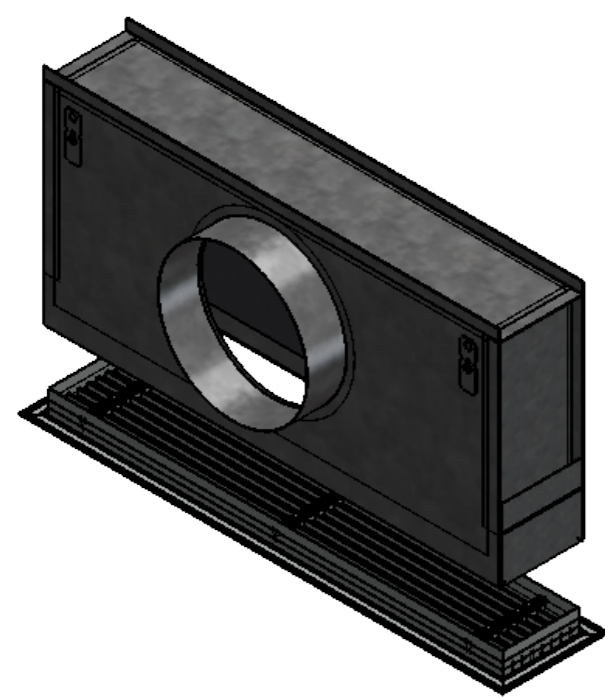

- 4900 Series Linear Grille Assembly Method to Prefixed Plenum:
1. Assembly components provided (screw through Linear Bar Grille into Concealed Fixing Bracket, using minimal number of turns to gain adequate purchase,
 2. Offer Linear Bar Grille to Plenum and push brackets through to locate in hemmed edge of plenum,
 3. Tighten screws in sequence to required level.

Note; not available for grilles with 6mm spacing (i.e. 49-480 & 49-481)

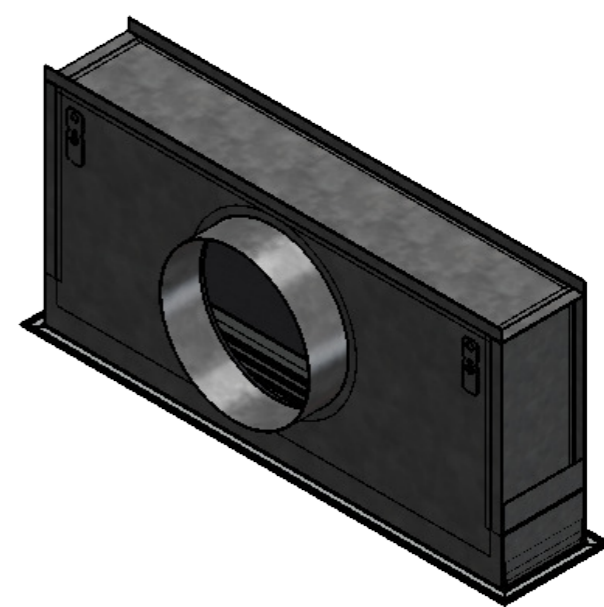

PRIVATE & CONFIDENTIAL NOT TO BE REPRODUCED WITHOUT THE PERMISSION OF ADVANCED AIR (UK) LTD.	TOLERANCES (Unless Otherwise Stated)
	0.0mm ± 0.5mm
	0.00mm ± 0.2mm
	Angles ± 0.5 Degrees
ADVANCED AIR (U.K.) LTD. RESERVE THE RIGHT TO MAKE DESIGN CHANGES WITHOUT NOTICE AS PART OF OUR CONTINUOUS IMPROVEMENT PROCESS.	

Advanced Air (U.K.) Limited
INNOVATION BY ACTION
 Reg'd Office: Burrell Way, Thetford,
 Norfolk, IP24 3QU, England
 Telephone : (01842) 765657 Fax : (01842) 753493

TITLE :
 4900P Series
 4900 Series Plenum - Concealed Fix Type
 Side Entry (49-200 A & B Frame Only)
 Customer Drawing

Date : 25/04/16	
Scale: 1:7	
Sheet 2 OF 2	
Drg. No. : 4900P CD001	A3

Rev.	Date	Change	Int.
A	26/04/16	First Issue	AF
B	14/09/16	ECN 929 - Grill neck height decreased	RJ

GA Details:

4900 Series Grille Neck Dimension	Nominal Spigot ϕ (mm)							
	ϕ 100	ϕ 150	ϕ 200	ϕ 250	ϕ 300	ϕ 350	ϕ 400	ϕ 450
Min to Max	150	200	250*	300	350	400	450	500
75 to 100mm	150	200	250*	300	350	400	450	500
101 to 150mm	200	200	250	300	350	400	450	500
151 to 200mm	250	250	250	300	350	400	450	500
201 to 250mm	300	300	300	300	350	400	450	500
251 to 300mm	350	350	350	350	350	400	450	500
301 to 350mm	400	400	400	400	400	400	450	500
351 to 400mm	450	450	450	450	450	450	450	500
401 to 450mm	500	500	500	500	500	500	500	500
451 to 500mm	550	550	550	550	550	550	550	550
501 to 550mm	600	600	600	600	600	600	600	600
551 to 600mm	650	650	650	650	650	650	650	650

- Note:
- Spot weld or button lock construction, Plenum shown is 600mm length with 200mm Spigot and 180mm height, with Dim. 'W' referring to a 4900 Series Linear Bar Grille with neck dimension 100mm.
 - For End Cap & Assembly details please see overleaf.
 - Dim. 'W' refers to neck dimension of 4900 Series Linear Bar Grille.

Material: 0.80mm Galvanised Mild Steel To BS EN 10346 : 2015 DX51 D + Z 275

Table 1; Table showing plenum depth from grille neck dimension and spigot size.
 Note; for irregular spigot size please use one spigot diameter up. (i.e. for ϕ 125mm please use ϕ 150mm).

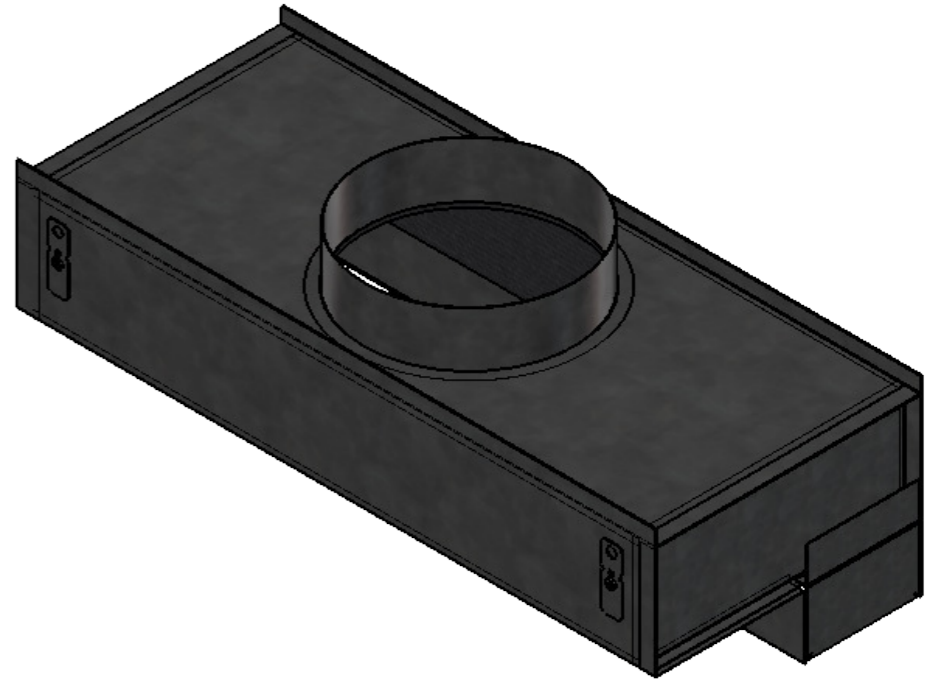
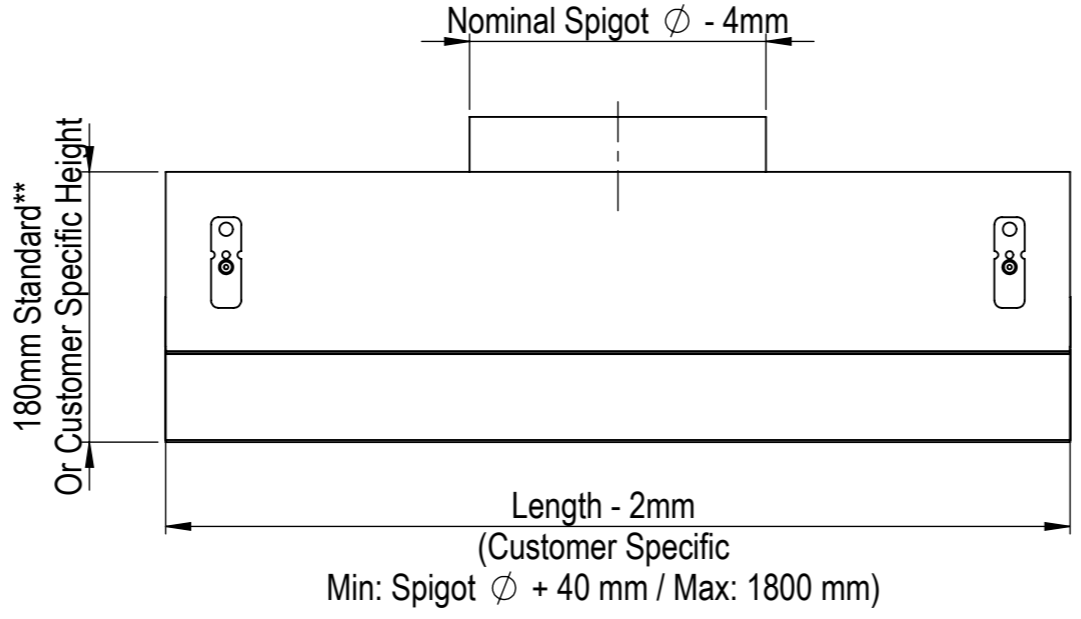
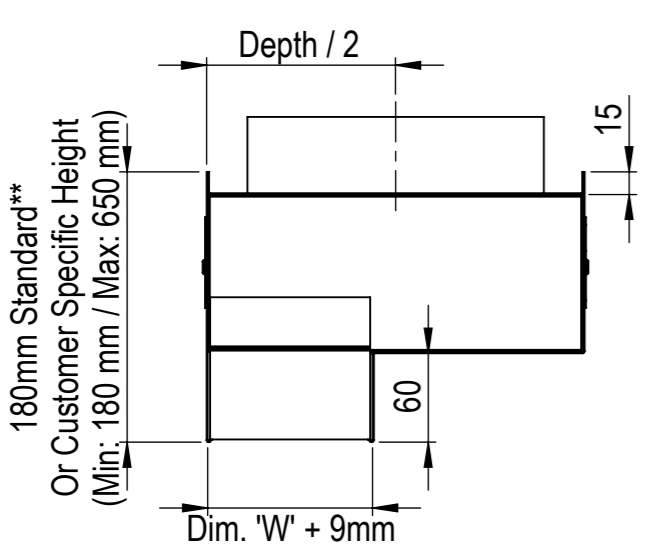

* Plenum depth shown
 ** 180 mm standard height has an internal plenum chamber height of 100mm.

PRIVATE & CONFIDENTIAL NOT TO BE REPRODUCED WITHOUT THE PERMISSION OF ADVANCED AIR (UK) LTD.	TOLERANCES (Unless Otherwise Stated)		 Advanced Air (U.K.) Limited Reg'd Office: Burrell Way, Thetford, Norfolk, IP24 3QU, England Telephone : (01842) 765657 Fax : (01842) 753493	TITLE : 4900P Series 4900 Series Plenum - Concealed Fix Type Top Entry (49-200 A & B Frame Only) Customer Drawing	Date : 26/04/16
	0.0mm \pm 0.5mm				Scale: 1:5
	0.00mm \pm 0.2mm				Sheet 1 OF 2
	Angles \pm 0.5 Degrees				Drg. No. : 4900P CD002
ADVANCED AIR (U.K.) LTD. RESERVE THE RIGHT TO MAKE DESIGN CHANGES WITHOUT NOTICE AS PART OF OUR CONTINUOUS IMPROVEMENT PROCESS.					A3

Rev.	Date	Change	Int.
A	26/04/16	First Issue	AF
B	14/09/16	ECN 929 - Grill neck height decreased	RJ

End Cap Configuration Details:

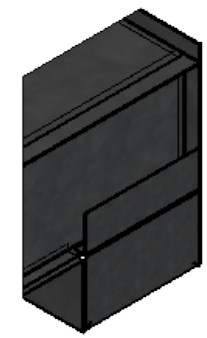

Plenum End Cap As Supplied
(With or Without OBD)

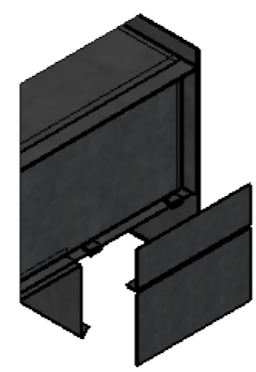

Remove Plenum
End Cap

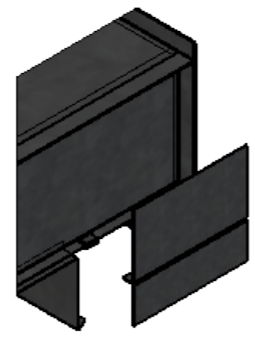

Invert Plenum End Cap
(Rotate 180°)

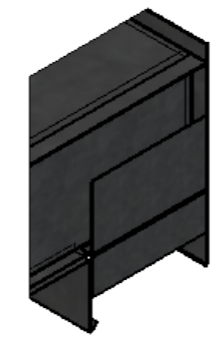

Refit for Intermediate Plenum
Without OBD

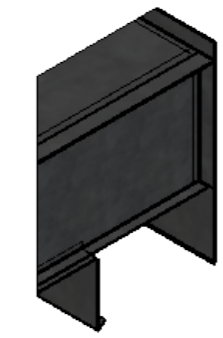

Remove End Cap and Discard
for Intermediate Plenum With
OBD

Assembly Details:

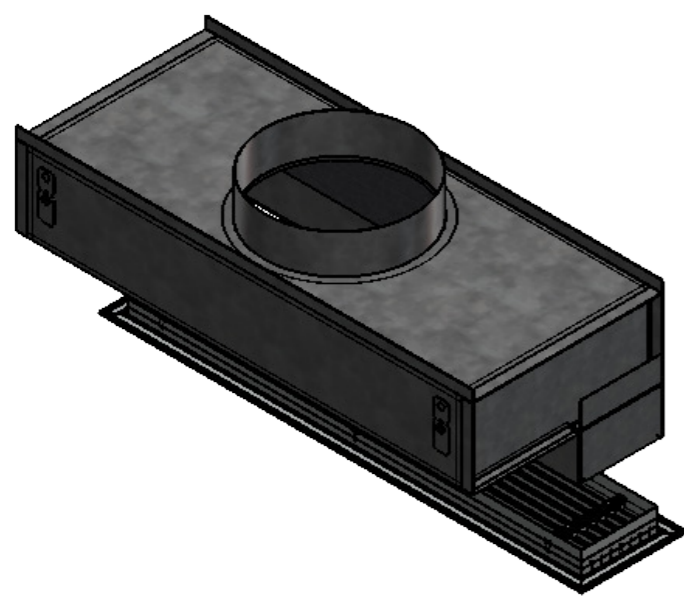

- 4900 Series Linear Grille Assembly Method to Prefixed Plenum:
1. Assembly components provided (screw through Linear Bar Grille into Concealed Fixing Bracket, using minimal number of turns to gain adequate purchase,
 2. Offer Linear Bar Grille to Plenum and push brackets through to locate in hemmed edge of plenum,
 3. Tighten screws in sequence to required level.

Note; not available for grilles with 6mm spacing (i.e. 49-480 & 49-481)

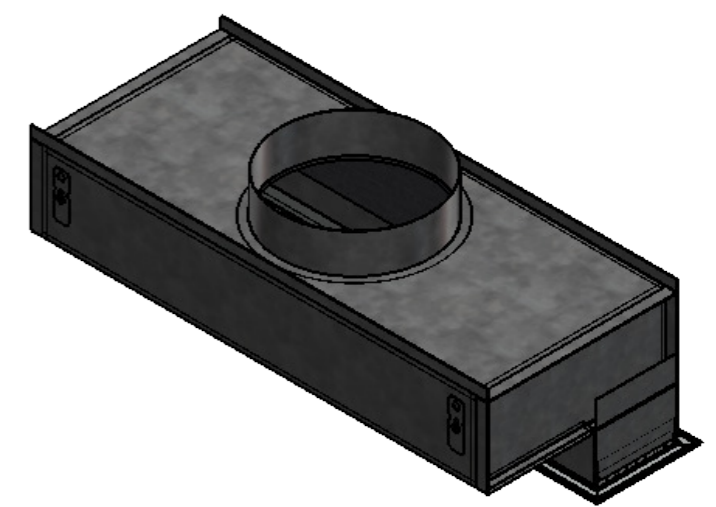

PRIVATE & CONFIDENTIAL
NOT TO BE
REPRODUCED WITHOUT
THE PERMISSION OF
ADVANCED AIR (UK) LTD.

TOLERANCES (Unless Otherwise Stated)
0.0mm ± 0.5mm
0.00mm ± 0.2mm
Angles ± 0.5 Degrees

Advanced Air (U.K.) Limited
 Reg'd Office: Burrell Way, Thetford,
 Norfolk, IP24 3QU, England
 Telephone : (01842) 765657 Fax : (01842) 753493

TITLE :
 4900P Series
 4900 Series Plenum - Concealed Fix Type
 Top Entry (49-200 A & B Frame Only)
 Customer Drawing

Date : 26/04/16	
Scale: 1:7	
Sheet 2 OF 2	
Drg. No. : 4900P CD002	A3